



*An Online CPD Course  
brought to you by  
CEDengineering.ca*

# Electrical Test Instruments and Measuring Devices

Course No: E02-003  
Credit: 2 PDH

---

Gilbert Gedeon, P.E.

---



Continuing Education and Development, Inc.

P: (877) 322-5800  
[info@cedengineering.ca](mailto:info@cedengineering.ca)

*This course was adapted from the Department of Energy, Publication No. DOE-HDBK-1011/2-92, "Electrical Science", Module 14, which is in the public domain.*

## TABLE OF CONTENTS

REFERENCES .....	iii
METER MOVEMENTS .....	1
D'Arsonval Movement .....	1
Electrodynamometer Movement .....	2
Moving Iron Vane Movement .....	3
Summary .....	4
VOLTMETERS .....	5
Voltmeters .....	5
Summary .....	9
AMMETERS .....	10
Ammeters .....	10
Summary .....	14
OHM METERS .....	15
Ohm Meters .....	15
Summary .....	19
WATTMETERS .....	20
Wattmeters .....	20
Three-Phase Wattmeter .....	21
Summary .....	22

**TABLE OF CONTENTS (Cont.)**

OTHER ELECTRICAL MEASURING DEVICES ..... 23

    Ampere-Hour Meter ..... 23

    Power Factor Meter ..... 24

    Ground Detector ..... 24

    Synchroscope ..... 26

    Summary ..... 27

TEST EQUIPMENT ..... 28

    Multimeter ..... 28

    Megger ..... 28

    Summary ..... 30

## **REFERENCES**

---

- Gussow, Milton, Schaum's Outline Series, Basic Electricity, McGraw-Hill.
- Academic Program for Nuclear Power Plant Personnel, Volume IV, Columbia, MD: General Physics Corporation, Library of Congress Card #A 326517, 1982.
- Academic Program for Nuclear Power Plant Personnel, Volume II, Columbia, MD: General Physics Corporation, Library of Congress Card #A 326517, 1982.
- Nasar and Unnewehr, Electromechanics and Electric Machines, John Wiley and Sons.
- Van Valkenburgh, Nooger, and Neville, Basic Electricity, Vol. 5, Hayden Book Company.
- Lister, Eugene C., Electric Circuits and Machines, 5<sup>th</sup> Edition, McGraw-Hill.
- Croft, Carr, Watt, and Summers, American Electricians Handbook, 10<sup>th</sup> Edition, McGraw-Hill.
- Mason, C. Russel, The Art and Science of Protective Relaying, John Wiley and Sons.
- Mileaf, Harry, Electricity One - Seven, Revised 2<sup>nd</sup> Edition, Hayden Book Company.
- Buban and Schmitt, Understanding Electricity and Electronics, 3<sup>rd</sup> Edition, McGraw-Hill.
- Kidwell, Walter, Electrical Instruments and Measurements, McGraw-Hill.

## METER MOVEMENTS

*There are three basic meter movements utilized in electrical meters: D'Arsonval, electro-dynamometer, and the moving iron vane. Some meter movements can be used for both AC or DC measurements, but in general, each meter movement is best suited for a particular type.*

**EO 1.1      EXPLAIN the following meter movements:**

- a.      D'Arsonval**
- b.      Electro-dynamometer**
- c.      Moving iron vane**

### D'Arsonval Movement

The most commonly used sensing mechanism used in DC ammeters, voltmeters, and ohm meters is a current-sensing device called a D'Arsonval meter movement (Figure 1). The D'Arsonval movement is a DC moving coil-type movement in which an electromagnetic core is suspended between the poles of a permanent magnet.

The current measured is directed through the coils of the electromagnet so that the magnetic field produced by the current opposes the field of the permanent magnet and causes rotation of the core. The core is restrained by springs so that the needle will deflect or move in proportion to the current intensity. The more current applied to the core, the stronger the opposing field, and the larger the deflection, up to the limit of the current capacity of the coil. When the current is interrupted, the opposing field collapses, and the needle is returned to zero by the restraining springs. The limit of the current that can be applied to this type movement is usually less than one milliamper.

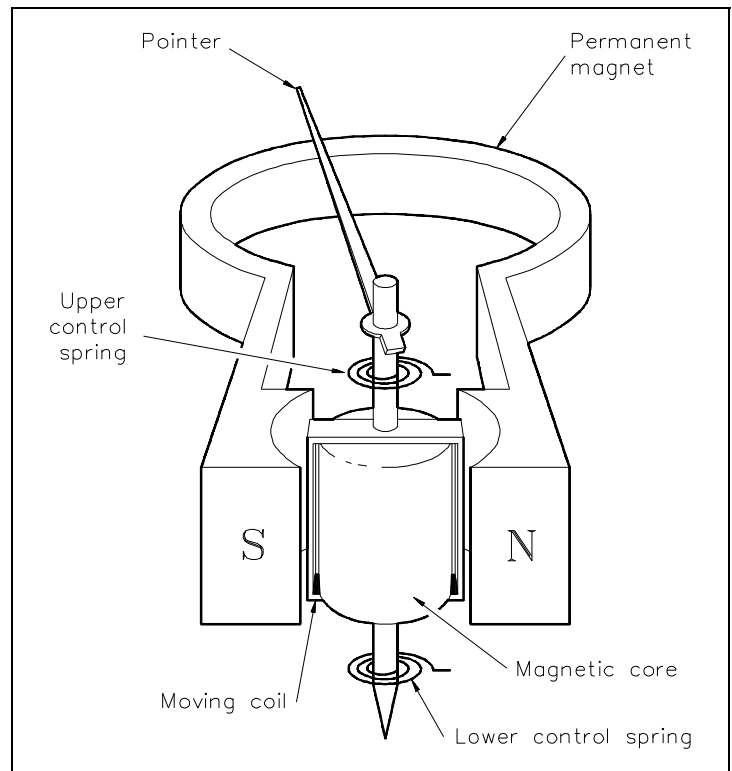

Figure 1 D'Arsonval Meter Movement

A common variation of the D'Arsonval movement is the Weston movement, which uses essentially the same principle built to a more rugged construction by employing jeweled supports for the core and employing a heavier winding in the electromagnet. Remember that the D'Arsonval movement is a DC device and can only measure DC current or AC current rectified to DC.

### **Electrodynamometer Movement**

The electrodynamicometer movement (Figure 2) has the same basic operating principle as the D'Arsonval meter movement, except that the permanent magnet is replaced by fixed coils. The moving coil and pointer, which are attached to the coil, are suspended between and connected in series with the two field coils. The two field coils and moving coil are connected in series such that the same current flows through each coil.

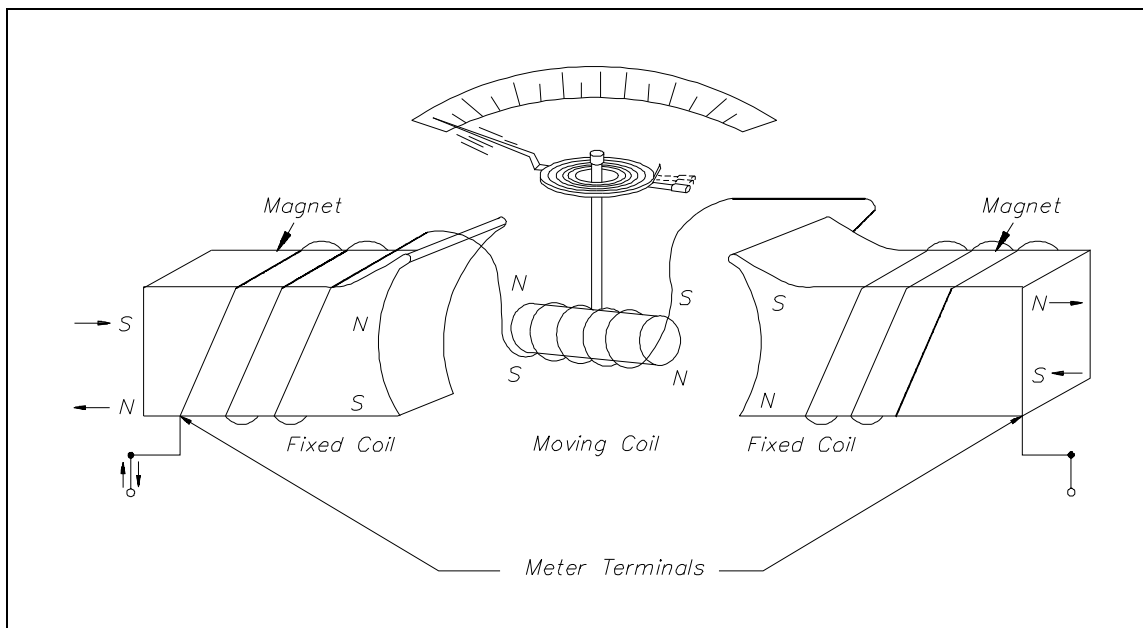

Figure 2 Electrodynamicometer Movement

Current flow through the three coils in either direction causes a magnetic field to be produced between the field coils. The same current flow through the moving coil causes it to act as a magnet exerting a force against the spring. If the current is reversed, the field polarity and the polarity of the moving coil reverse, and the force continues in the same direction. Due to this characteristic of the electrodynamicometer movement, it can be used in both AC and DC systems to measure current. Some voltmeters and ammeters use the electrodynamicometer. However, its most important use is in the wattmeter, which will be discussed later in this module.

## Moving Iron Vane Movement

The moving iron vane movement (Figure 3) can be used to measure both AC current and voltage. By changing the meter scale calibration, the movement can be used to measure DC current and voltage. The moving iron vane meter operates on the principle of magnetic repulsion between like poles. The measured current flows through a field coil which produces a magnetic field proportional to the magnitude of current. Suspended in this field are two iron vanes. One vane is held in a fixed position and does not move while the other vane is attached to the moveable pointer. The magnetic field produced by the current flow magnetizes the two iron vanes with the same polarity regardless of the direction of current through the coil. Since like poles repel one another, the moving iron vane pulls away from the fixed vane and moves the meter pointer. This motion exerts a force against a spring. The distance the moving iron vane will travel against the spring depends on the strength of the magnetic field. The strength of the magnetic field depends on the magnitude of current flow.

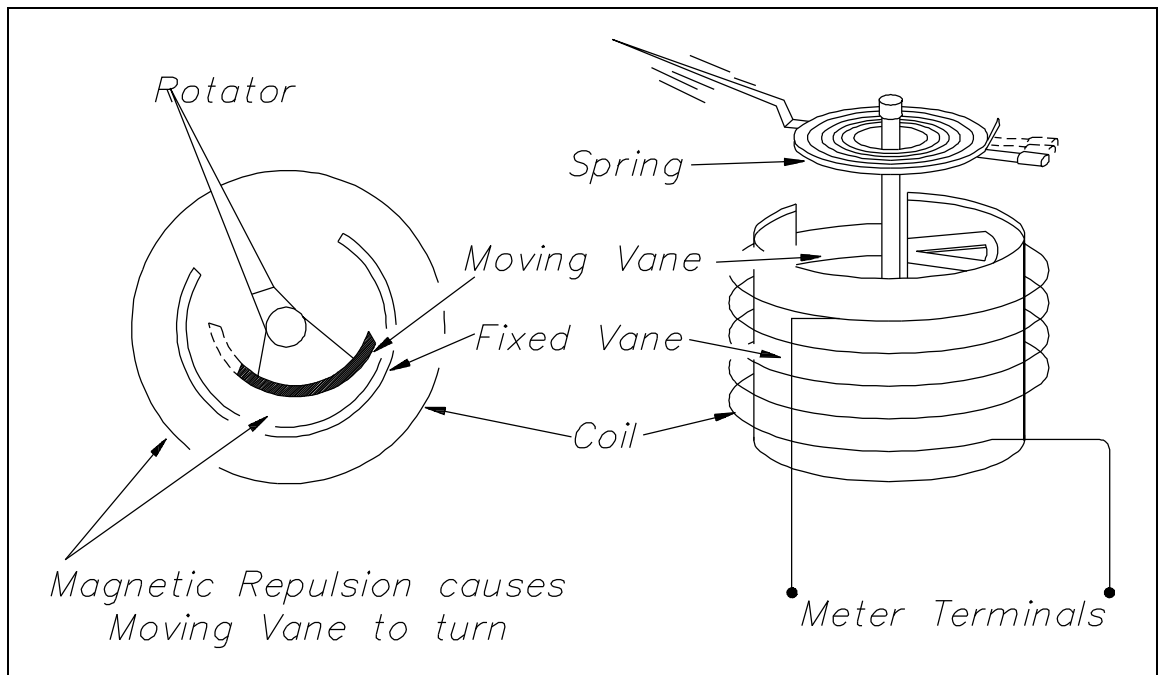

Figure 3 Moving Iron Vane Meter Movement

As stated previously, this type of meter movement may also be used to measure voltage. When this type of movement is used to measure voltage, the field coil consists of many turns of fine wire used to generate a strong magnetic field with only a small current flow.



## **Summary**

Meter movements are summarized below.

### **Meter Movement Summary**

- D'Arsonval - A DC moving coil movement where the moving coil is suspended between the poles of a permanent magnet restrained by helical springs, and the measured current flowing through the moving coil produces a torque on the attached pointer proportional to the current.
- Electrodynamometer - The moving coil and attached pointer are suspended between and connected in series with the two stationary field coils so that the same current flows through each. A measured current flowing through the three coils in either direction causes a magnetic repulsion between the field coils and the moving coil. The magnetic repulsion exerts a force against the spring and provides a measurement of either DC or AC current.
- Moving iron vane - The moving iron vane meter operates on the principle of magnetic repulsion between like poles. The measured current flows through a field coil which induces a like magnetic field into a fixed and moving vane causing the moving vane to deflect a pointer in proportion to the current or voltage applied to the coil.



$$V = I_m R_s + I_m R_m$$

$$I_m R_s = V - I_m R_m$$

$$R_s = \frac{V}{I_m} - R_m \quad (14-1)$$

where

V = voltage range desired

$I_m$  = meter current

$R_m$  = meter resistance

$R_s$  = multiplier resistance or series resistance

Example: A 2 mA meter movement with internal resistance of 25 ohms is to be constructed as a voltmeter.

What value must the series resistance be to measure full scale voltage of 100 volts?

Solution:

$$R_s = \frac{V}{I_m} - R_m$$

Since  $R_m$  is negligibly low, then:

$$\begin{aligned} R_s &= \frac{V}{I_m} \\ &= \frac{100}{2 \times 10^{-3}} \end{aligned}$$

$$R_s = 50 \text{ k}\Omega$$

When a voltmeter is connected in a circuit, the voltmeter will draw current from that circuit. This current causes a voltage drop across the resistance of the meter, which is subtracted from the voltage being measured by the meter. This reduction in voltage is known as the loading effect and can have a serious effect on measurement accuracy, especially for low current circuits.

The accuracy of a voltmeter ( $K_v$ ) is defined as the ratio of measured voltage when the meter is in the circuit ( $V_w$ ) to the voltage measured with the meter out of the circuit. Equation (14-2) is a mathematical representation of the accuracy of a voltmeter, or true voltage ( $V_o$ ).

$$K_v = \frac{V_w}{V_o} \quad (14-2)$$

Meter accuracy can also be determined by comparing the relationship between the input and circuit resistances using Ohm's Law as described below.

$$\begin{aligned} K_v &= \frac{V_w}{V_o} & V_w &= I_m R_{in} \\ &= \frac{I_m R_{in}}{V_o} & I_m &= \frac{V_o}{R_o + R_{in}} \\ &= \frac{\left( \frac{V_o \cdot R_{in}}{R_o + R_{in}} \right)}{V_o} \\ K_v &= \frac{R_{in}}{R_o + R_{in}} \end{aligned}$$

where

- $I_m$  = meter current
- $V_o$  = true voltage
- $R_o$  = circuit resistance
- $R_{in}$  = input resistance of the voltmeter
- $K_w$  = indicated voltage
- $K_v$  = meter accuracy

Example: A voltmeter in the 100 volt range with a sensitivity of  $40 \text{ K}\Omega/\text{V}$  is to measure the voltage across terminals ab (Figure 5).

- Find: 1.  $V_o$   
 2.  $V_w$   
 3.  $K_v$

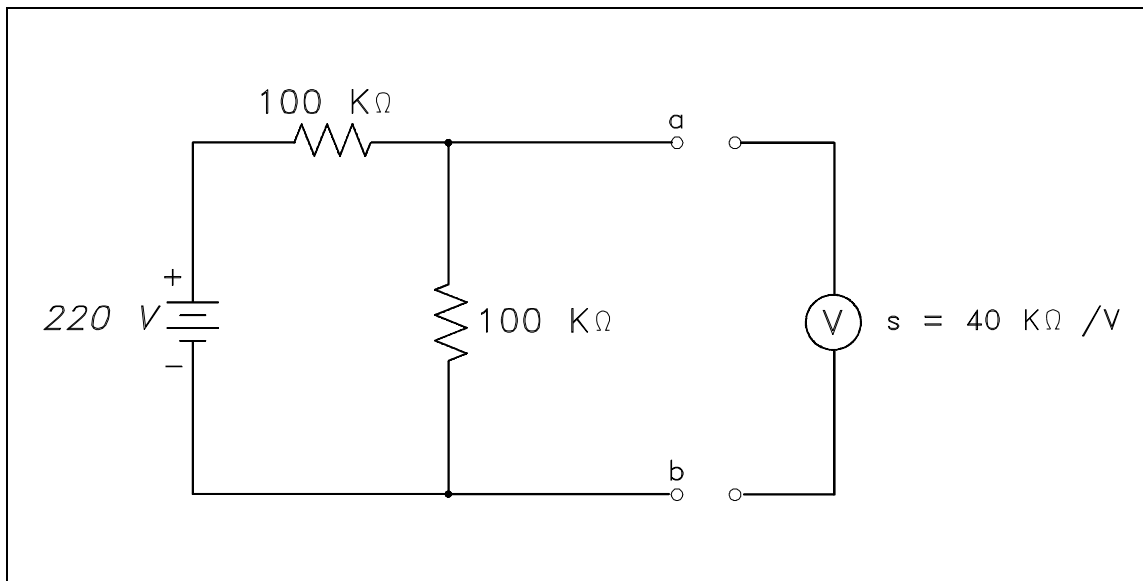

Figure 5 Measuring Circuit Voltage

Solution:

$$1. \quad V_o = \frac{100\text{K}\Omega}{100\text{K}\Omega + 100\text{K}\Omega} \times 220\text{V}$$

$$V_o = 110 \text{ volts}$$

$$2. \quad R_o = \frac{(100)(100)}{100 + 100} = 50 \text{ K}\Omega \quad R_{in} = SV = (40 \text{ K}\Omega/\text{V})(100 \text{ V}) = 4 \text{ M}\Omega$$

$$V_w = \frac{R_{in}}{R_o + R_{in}} V_o$$
$$= \left( \frac{4.4 \times 10^6}{50 \times 10^3 + 4.4 \times 10^6} \right) (110)$$
$$= (0.99)(110)$$

$$V_w = 108.9 \text{ volts}$$

$$3. \quad K_v = \frac{V_w}{V_o}$$

$$= \frac{108.9}{110}$$

$$K_v = 0.99 \text{ or } 99\%$$

### Summary

Voltmeters are summarized below.

#### **Voltmeter Summary**

- Measures voltage
- Connected in parallel with the load being measured

## AMMETERS

*Measurement of current being supplied to or from a component is measured by an ammeter.*

**EO 1.2 STATE the electrical parameters measured by each of the following in-place measuring devices:**

**b. Ammeter**

**EO 1.3 EXPLAIN how the following electrical test equipment and measuring devices are connected to a circuit:**

**b. Ammeter**

### Ammeter

The ammeter measures electric current. It may be calibrated in amperes, milliamperes, or microamperes. In order to measure current, the ammeter must be placed in series with the circuit to be tested (Figure 6).

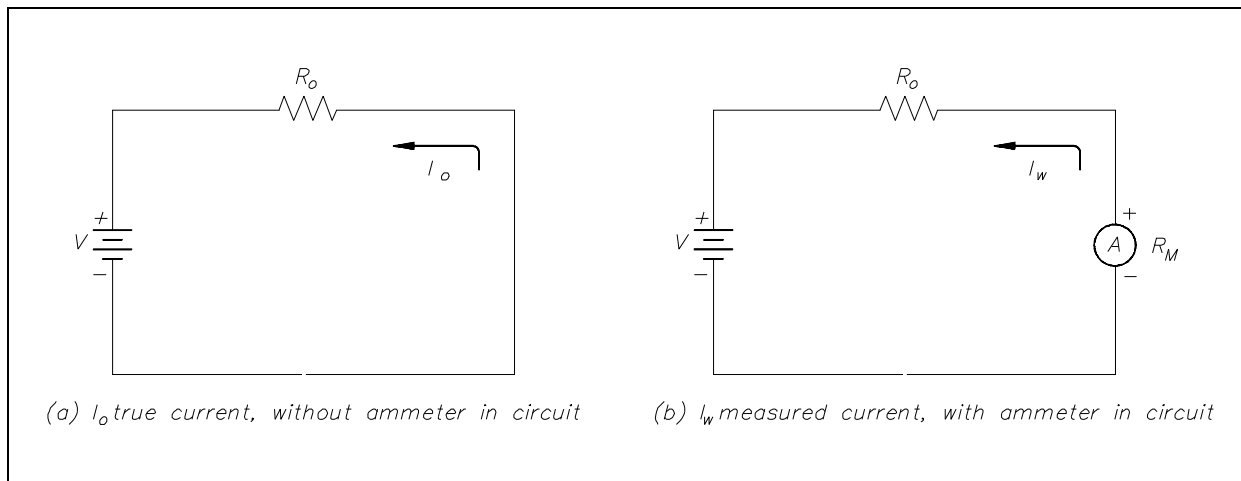

Figure 6 Ammeter

When an ammeter is placed in series with a circuit, it will increase the resistance of that circuit by an amount equal to the internal resistance of the meter  $R_m$ . Equation (14-3) is the mathematical representation of the current without the meter installed.

$$I_o = \frac{V}{R_o} \quad (14-3)$$

Equation (14-4) is the mathematical representation of the current with the meter installed in the circuit.

$$I_w = \frac{V}{R_o + R_m} \quad (14-4)$$

The accuracy of the ammeter  $K_A$  is the ratio of the current when the meter is in the circuit,  $I_w$ , to the current with the meter out of the circuit,  $I_o$ . Equation (14-5) is the mathematical representation for solving for the accuracy of the ammeter ( $K_A$ ).

$$K_A = \frac{I_w}{I_o} \quad (14-5)$$

By substitution laws, Equation (14-6) is a mathematical representation of the accuracy using circuit resistance.

$$K_A = \left( \frac{V}{R_o + R_m} \right) \left( \frac{R_o}{V} \right) = \frac{R_o}{R_o + R_m} \quad (14-6)$$

The percent loading error is that percent of error due to loading effects that result from the added resistance of the meter. Equation (14-7) is a mathematical representation of the percent loading error.

$$\% \text{ loading error} = (1 - K_A)(100 \%) \quad (14-7)$$

A second error which occurs in an ammeter is calibration error. Calibration error is an error that occurs due to inaccurately marked meter faces. Typical values of calibration error in terms of full scale current are about 3 percent.

Example: An ammeter, with a 10 mA full scale deflection and an internal resistance of 400  $\Omega$ , is placed in a circuit with a 20 V power source and a 2 K $\Omega$  resistor (Figure 7).

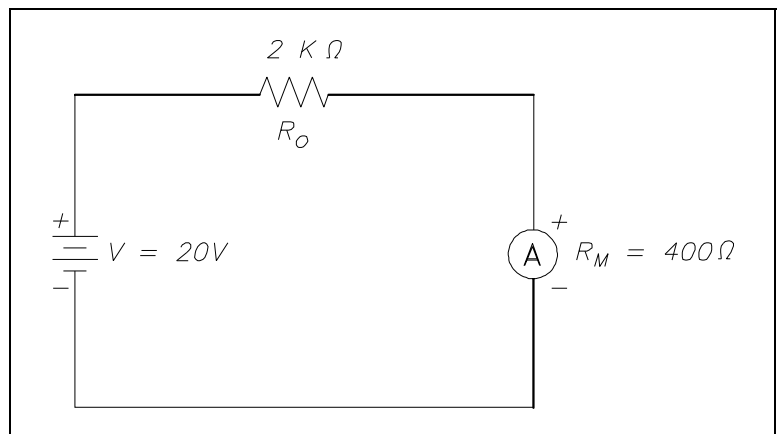

Figure 7 Ammeter Accuracy



- Find:
1. accuracy
  2. %loading error
  3. true current
  4. measured current

1. 
$$K_A = \frac{R}{R_o + R_m}$$

$$K_A = \frac{2000}{2000 + 400}$$

$$K_A = 0.833 \text{ or } 83.3\%$$

2. % loading error =  $(1 - K_A)(100\%)$

$$\% \text{ loading error} = (1 - 0.833)(100\%)$$

$$\% \text{ loading error} = 16.7\%$$

3. 
$$I_o = \frac{V}{R_o}$$

$$= \frac{20}{2000}$$

$$I_o = 0.01 \text{ A or } 10 \text{ mA}$$

4. 
$$I_w = \frac{V}{R_o + R_m}$$

$$= \frac{20}{2000 + 400}$$

$$I_w = 8.33 \times 10^{-3} \text{ A or } 8.33 \text{ mA}$$

An ammeter with a full scale  $I_m$  can be shunted with a resistor  $R_{SH}$  in order to measure currents in excess of  $I_m$  (Figure 8). The reason for shunting an ammeter is to extend the range of the ammeter and, thereby, measure currents higher than the original full scale value.

By Kirchoff's current law,

$$I_{SH} = I_T - I_m$$

Since the voltage across the shunt must be equal to the voltage across the ammeter, shunt resistance is calculated as follows:

$$I_{SH} R_{SH} = I_m R_m$$

$$R_{SH} = \frac{I_m R_m}{I_{SH}}$$

$$R_{SH} = \frac{I_m R_m}{I_T - I_m}$$

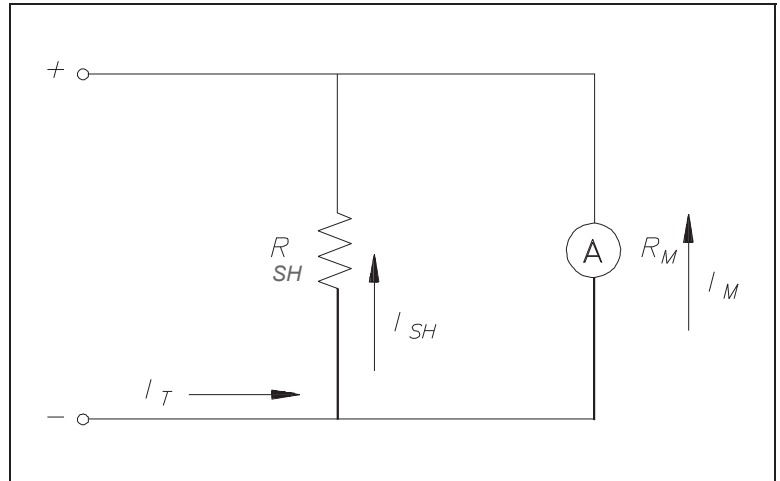

Figure 8 Ammeter with Shunt

Therefore, the input resistance of a shunted ammeter is related to the meter and shunt resistance. Equation (14-8) is a mathematical representation of this relationship.

NOTE: When computing accuracy for a shunted ammeter, use  $R_m^1$  in place of  $R_m$ .

$$R_m^1 = \frac{R_m R_{SH}}{R_m + R_{SH}} \quad (14-8)$$

Equation (14-9) is a mathematical representation of the relationship between input voltage and current to the ammeter and the value of input resistance.

$$R_m^1 = \frac{V_{in}}{I_{in}} = \frac{I_m R_m}{I_T} \quad (14-9)$$

Example: An ammeter, with a  $100 \Omega$  meter resistance and a full scale deflection current of 4 mA, is to be shunted to measure currents from 1 to 20 mA.

- Find: 1.  $R_{SH}$   
 2.  $R_m^1$

Solution:

$$\begin{aligned} 1. \quad R_{SH} &= \frac{I_m R_m}{I_T - I_m} \\ &= \frac{(4)(100)}{20 - 4} \end{aligned}$$

$$R_{SH} = 25 \Omega$$

$$\begin{aligned} 2. \quad R_m^1 &= \frac{I_m R_m}{I_T} \\ &= \frac{(4)(100)}{20} \end{aligned}$$

$$R_m^1 = 20 \Omega$$

## **Summary**

Ammeters are summarized below.

### **Ammeter Summary**

- Measure circuit current flow
- Connected in series with the circuit

## OHM METERS

*The resistance of a wire or a circuit is measured by an ohm meter. An ohm meter aids the troubleshooter in determining if a ground or a short exists in a circuit.*

**EO 1.2 STATE the electrical parameters measured by each of the following in-place measuring devices:**

c. Ohm meter

**EO 1.3 EXPLAIN how the following electrical test equipment and measuring devices are connected to a circuit:**

c. Ohm meter

### Ohm Meter

The ohm meter is an instrument used to determine resistance. A simple ohm meter (Figure 9) consists of a battery, a meter movement calibrated in ohms, and a variable resistor.

Ohm meters are connected to a component which is removed from the circuit as illustrated in Figure 9. The reason for removing the component is that measurement of current through the component determines the resistance. If the component remains in the circuit, and a parallel path exists in the circuit, the current will flow in the path of least resistance and give an erroneous reading.

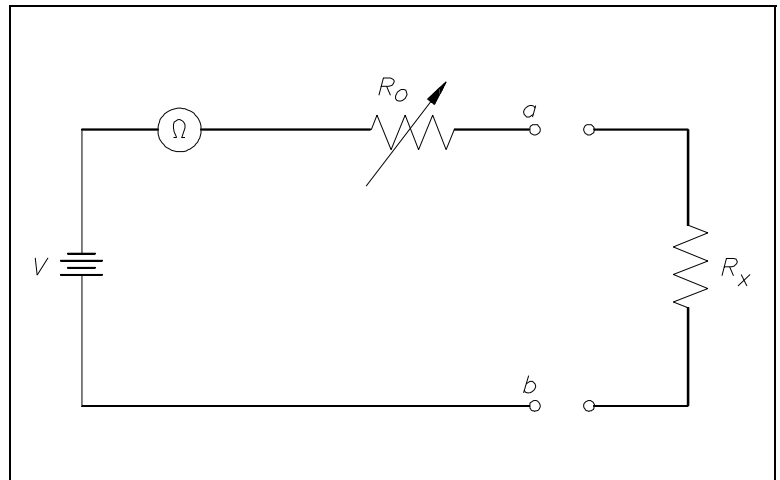

Figure 9 Simple Ohm Meter Circuit

$R_o$ , in Figure 9, is an adjustable resistor whose purpose is to zero the ohm meter and correct for battery aging. It is also a current-limiting resistor which includes the meter resistance  $R_m$ . Zeroing the ohm meter is accomplished by shorting the ohm meter terminals  $ab$  and adjusting  $R_o$  to give full-scale deflection.

Equation (14-10) is the mathematical representation for determining full-scale deflection meter current.

$$I_m = \frac{V}{R_o} \quad (14-10)$$

When the unknown resistance  $R_x$  is connected across the ohm meter terminals, the current is measured by calculating the total series resistance and applying Equation (14-10). Equation (14-11) is the mathematical representation of this concept.

$$I = \frac{V}{R_o + R_x} \quad (14-11)$$

An easy way to determine ohm meter deflection is by use of a deflection factor (D). Deflection factor is the ratio of circuit current to meter current. Equation (14-12) is the mathematical representation of the deflection factor.

$$D = \frac{I}{I_m} = \frac{\frac{V}{R_o + R_x}}{\frac{V}{R_o}} = \frac{R_o}{R_o + R_x} \quad (14-12)$$

The current through the circuit can be determined by solving for I. Equation (14-13) is the mathematical representation of this relationship.

$$I = DI_m \quad (14-13)$$

To solve for  $R_x$  using Equations (14-10) through (14-13), the relationship between deflection factor and the meter resistance to the unknown resistance can be shown. Equation (14-14) is the mathematical representation of this relationship.

$$R_x = \frac{1 - D}{D} R_o \quad (14-14)$$

If half-scale deflection occurs, then  $R_x = R_o$ , so that the value of  $R_o$  is marked at mid-scale on the ohm meter face.

Example 1: An ohm meter has a meter movement with a 100  $\mu\text{A}$  full-scale deflection. The open circuit voltage at terminals ab is 24 V. The ohm meter is zeroed and then an unknown resistance  $R_x$  is measured, which produces quarter-scale deflection. Find  $R_x$ .

Solution:

First find  $R_o$ .

$$R_o = \frac{V}{I_m}$$
$$= \frac{24}{1 \times 10^{-6}}$$

$$R_o = 2.4 \times 10^5 \Omega \text{ or } 240 \text{ K}\Omega$$

Then solve for  $R_x$ :

$$R_x = \frac{1 - D}{D} R_o$$
$$= \left( \frac{1 - \frac{1}{4}}{\frac{1}{4}} \right) (240)$$
$$= (3)(240)$$
$$R_x = 720 \text{ K}\Omega$$

Therefore, quarter scale deflection of this ohm meter face would read 720  $\text{K}\Omega$ .

Example 2: An ohm meter with  $R_o = 30 \Omega$ , and full scale current  $I_m = 300 \mu\text{A}$ . Find I with: 1) 0  $\Omega$ , 2) 5  $\Omega$ , 3) 10  $\Omega$ , 4) 15  $\Omega$ , and 5) 1  $\text{M}\Omega$  resistors across the meter terminal.

Solution:

First, the deflection factor for each resistor must be found.

$$D = \frac{R_o}{R_o + R_x}$$

1.  $R_x = 0 \Omega$   
 $D = \frac{30}{30} = 1$
2.  $R_x = 5 \Omega$   
 $D = \frac{30}{30 + 5} = 0.86$
3.  $R_x = 10 \Omega$   
 $D = \frac{30}{30 + 10} = 0.75$
4.  $R_x = 15 \Omega$   
 $D = \frac{30}{30 + 15} = 0.67$
5.  $R_x = 1 \text{ M}\Omega$   
 $D = \frac{30}{1 \times 10^6} = 1 \times 10^{-6} = 0.000001$  approximately 0

Then find I by using:

$$I = DI_m$$

1.  $R_x = 0 \Omega$   
 $I = (1)(300 \times 10^{-6}) = 300 \mu\text{A}$  full-scale deflection
2.  $R_x = 5 \Omega$   
 $I = (0.86)(300 \times 10^{-6}) = 258 \mu\text{A}$
3.  $R_x = 10 \Omega$   
 $I = (0.75)(300 \times 10^{-6}) = 225 \mu\text{A}$
4.  $R_x = 15 \Omega$   
 $I = (0.67)(300 \times 10^{-6}) = 201 \mu\text{A}$
5.  $R_x = 1 \text{ M}\Omega$   
 $I = (0)(300 \times 10^{-6}) = 0 \mu\text{A}$  zero deflection

NOTE: As the resistance was increased from 0 to  $5\Omega$ , meter current decreased by  $42\ \mu\text{A}$ . Similarly, when resistance was increased from 5 to  $10\Omega$ , the current decreased by  $33\ \mu\text{A}$ . Thus, an ammeter scale used to measure resistance is nonlinear (Figure 10). The ohm meter scale is a reversal of the ammeter and voltmeter scales. In other words, the zero resistance ( $R_x = 0$ ) is at the right end of the scale and infinite resistance ( $R_x = 1\ \text{M}\Omega$ ) is at the left end of the scale.

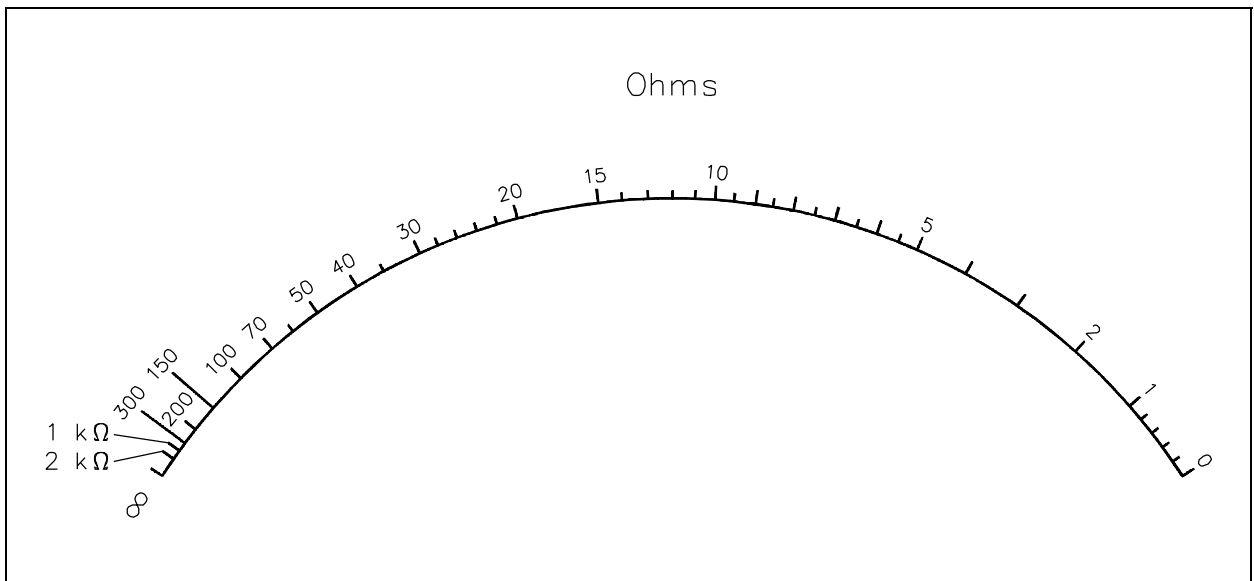

Figure 10 Ohm Meter Scale

## Summary

Ohm meters are summarized below.

### **Ohm Meter Summary**

- Measures circuit resistance
- Connected to a component removed from the circuit



## WATTMETERS

Wattmeters are used to determine DC power or real AC power delivered to the load.

**EO 1.2 STATE the electrical parameters measured by each of the following in-place measuring devices:**

**d. Wattmeter**

**EO 1.3 EXPLAIN how the following electrical test equipment and measuring devices are connected to a circuit:**

**d. Wattmeter**

### Wattmeter

The wattmeter is an instrument which measures DC power or true AC power. The wattmeter uses fixed coils to indicate current, while the movable coil indicates voltage (Figure 11). Coils  $L_{I1}$  and  $L_{I2}$  are the fixed coils in series with one another and serve as an ammeter. The two I terminals are connected in series with the load. The movable coil  $L_V$ , and its multiplier resistor  $R_S$ , are used as a voltmeter, with the V terminals connected in parallel with the load. The meter deflection is proportional to the VI, which is power.

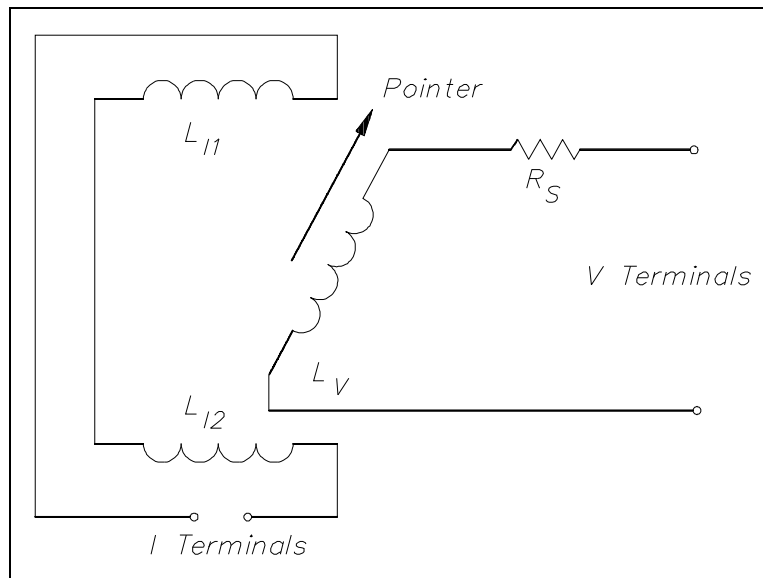

Figure 11 Wattmeter Schematic

Wattmeters are rated in terms of their maximum current, voltage, and power. All of these ratings must be observed to prevent damage to the meter.

Equation (14-15) is the mathematical representation of calculating power in a DC circuit.

$$P = VI \text{ or } P = I^2R \quad (14-15)$$

Equation (14-16) is the mathematical representation for calculating power in an AC circuit.

$$P = V_{\text{Rms}} I_{\text{Rms}} \cos \theta \text{ or } P = I^2 R \quad (14-16)$$

### Three-Phase Wattmeter

Total power in a 3 $\phi$  circuit is the sum of the powers of the separate phases. The total power could be measured by placing a wattmeter in each phase (Figure 12); however, this method is not feasible since it is often impossible to break into the phases of a delta load. It also may not be feasible for the Y load, since the neutral point to which the wattmeters must be connected is not always accessible.

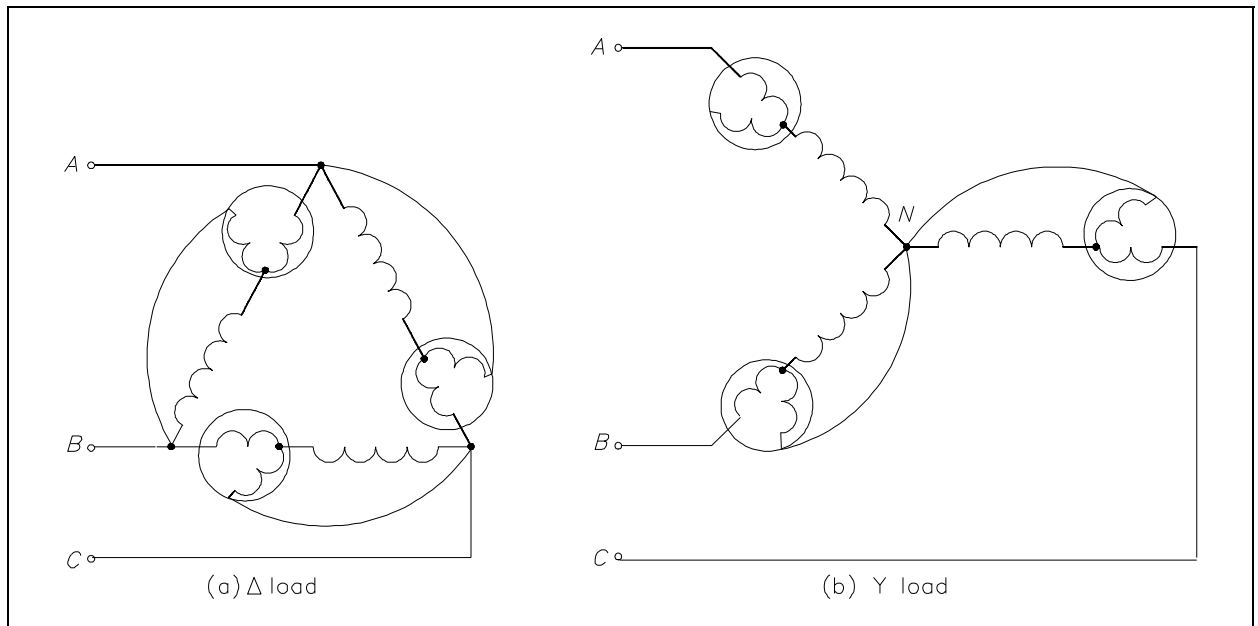

Figure 12 Wattmeters in Each Phase

Normally, only two wattmeters are used in making 3 $\phi$  power measurements (Figure 13).

In balanced 3 $\phi$  systems, with any power factor, total power is calculated by adding the A and B phase powers. Equation (14-17) is the mathematical representation for calculating total power ( $P_T$ ).

$$P_T = W_A + W_B \quad (14-17)$$

where

$W_A$  and  $W_B$  are the power readings in Phase A and Phase B

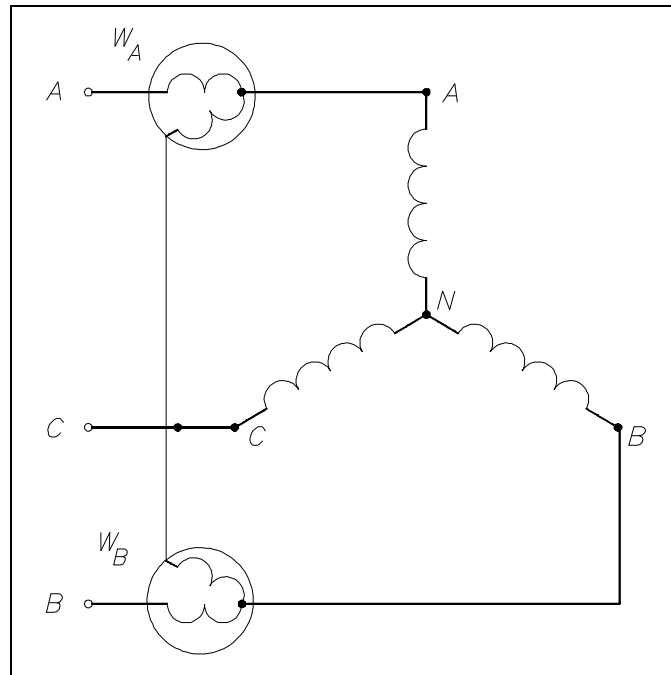

Figure 13 Two Wattmeters to Measure 3 $\phi$  Power

## Summary

Wattmeters are summarized below.

### **Wattmeter Summary**

- Measures real power delivered to the load
- Single-phase AC or DC - voltage component (movable coil) connected in parallel with the load and the current component (fixed coil) connected in series with the load
- Three-phase AC - summation of Phase A and B powers

## OTHER ELECTRICAL MEASURING DEVICES

---

*Other measuring devices are used to aid operators in determining the electric plant conditions at a facility, such as the ampere-hour meter, power factor meter, ground detector, and synchroscope.*

**EO 1.2 STATE the electrical parameters measured by each of the following in-place measuring devices:**

- e. Ampere-hour meter**
- f. Power factor meter**
- g. Ground detector**
- h. Synchroscope**

**EO 1.3 EXPLAIN how the following electrical test equipment and measuring devices are connected to a circuit:**

- e. Ampere-hour meter**
  - f. Power factor meter**
  - g. Ground detector**
  - h. Synchroscope**
- 

### Ampere-Hour Meter

The ampere-hour meter registers ampere-hours and is an integrating meter similar to the watt-hour meter used to measure electricity usage in a home. Typical ampere-hour meters are digital indicators similar to the odometer used in automobiles. The ampere-hour meter is a direct current meter that will register in either direction depending on the direction of current flow. For example, starting from a given reading, it will register the amount of discharge of a battery; when the battery is placed on charge, it will operate in the opposite direction, returning once again to its starting point. When this point is reached, the battery has received a charge equal to the discharge, and the charge is stopped. It is normally desired to give a battery a 10% overcharge. This is accomplished by designing the ampere-hour meter to run 10% slow in the charge direction. These meters are subject to inaccuracies and cannot record the internal losses of a battery. They attempt to follow the charge and discharge, but inherently do not indicate the correct state of charge. Similar to an ammeter, the ampere-hour meter is connected in series. Although the ampere-hour meters were used quite extensively in the past, they have been largely superseded by the voltage-time method of control.

## Power Factor Meter

A power factor meter is a type of electro-dynamometer movement when it is made with two movable coils set at right angles to each other. The method of connection of this type of power factor meter, in a 3 $\phi$  circuit, is shown in Figure 14. The two stationary coils, S and S<sup>1</sup>, are connected in series in Phase B. Coils M and M<sup>1</sup> are mounted on a common shaft, which is free to move without restraint or control springs. These coils are connected with their series resistors from Phase B to Phase A and from Phase B to Phase C. At a power factor of unity, one potential coil current leads and one lags the current in Phase B by 30°; thus, the coils are balanced in the position shown in Figure 14. A change in power factor will cause the current of one potential coil to become more in phase and the other potential coil to be more out of phase with the current in Phase B, so that the moving element and pointer take a new position of balance to show the new power factor.

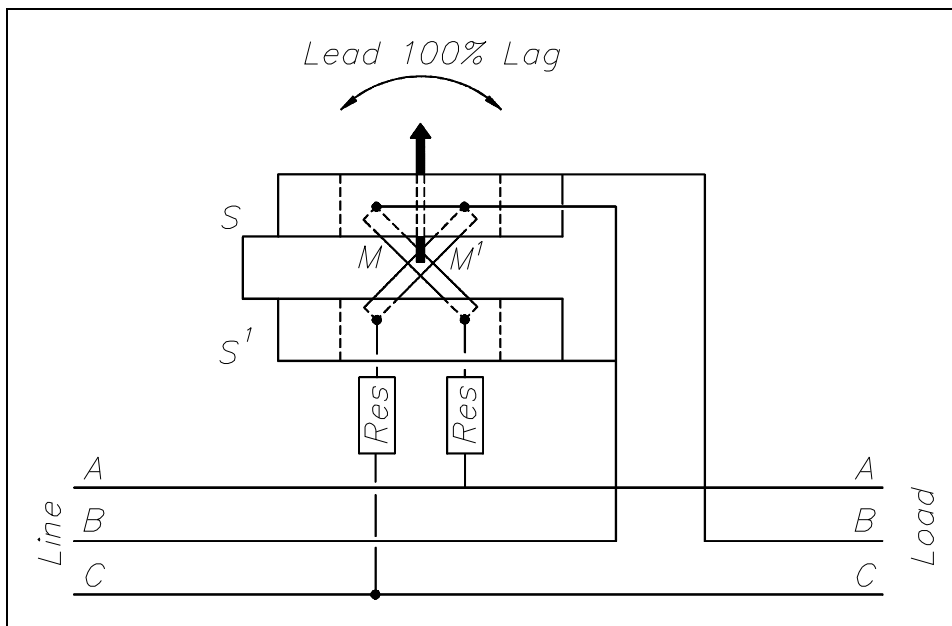

Figure 14 3 $\phi$  Power Factor Meter Schematic

## Ground Detector

The ground detector is an instrument which is used to detect conductor insulation resistance to ground. An ohm meter, or a series of lights, can be used to detect the insulation strength of an ungrounded distribution system. Most power distribution systems in use today are of the grounded variety; however, some ungrounded systems still exist.

In the ohm meter method (Figure 15), a DC voltage is applied to the conductor. If a leakage path exists between the conductor insulator and ground, a current will flow through the ground to the ohm meter proportional to the insulation resistance of the conductor.

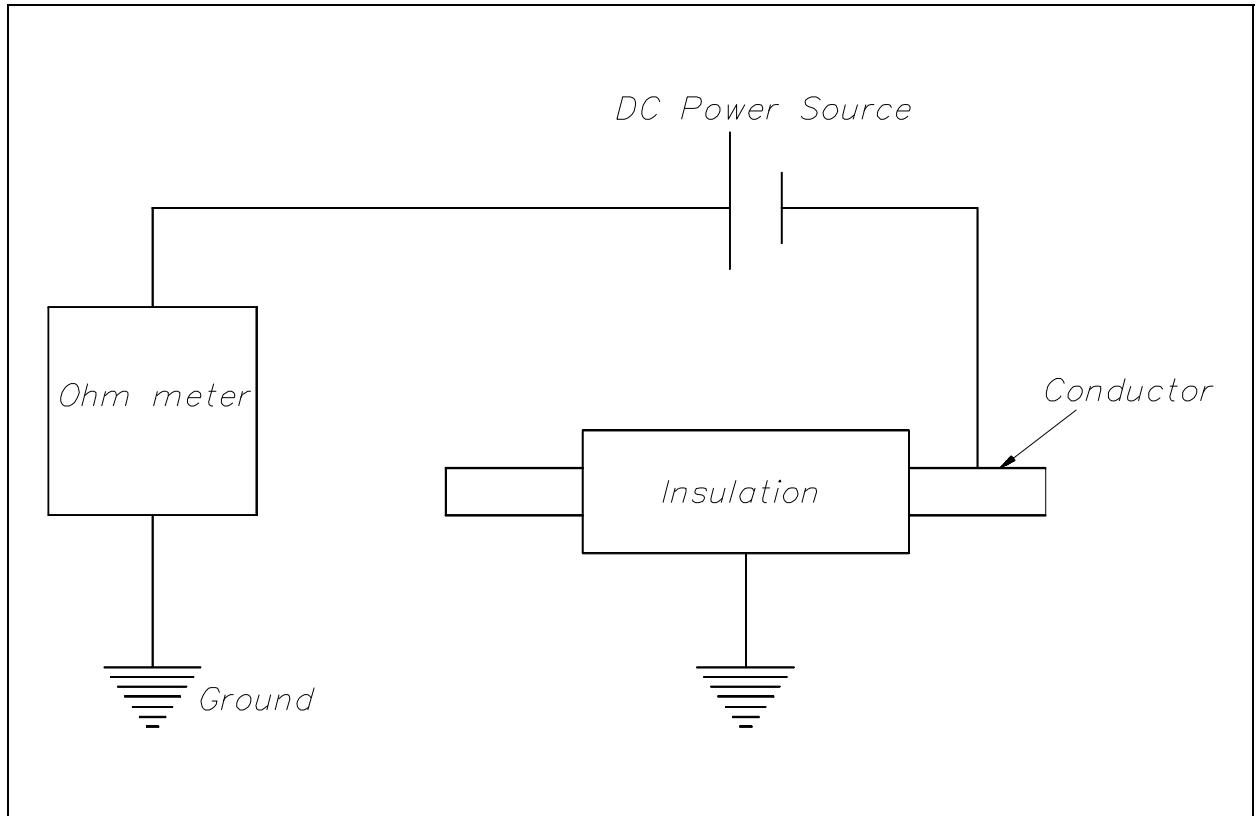

Figure 15 Simple Ohm Meter Ground Detector

In the ground detector lamp method (Figure 16), a set of three lamps connected through transformers to the system is used. To check for grounds, the switch is closed and the brilliance of the lamps is observed. If the lamps are equally bright, no ground exists and all the lamps receive the same voltage. If any one lamp is dark, and the other two lamps are brighter, the phase in which the darkened lamp is in is grounded. In this case, the primary winding of the transformer is shorted to ground and receives no voltage.

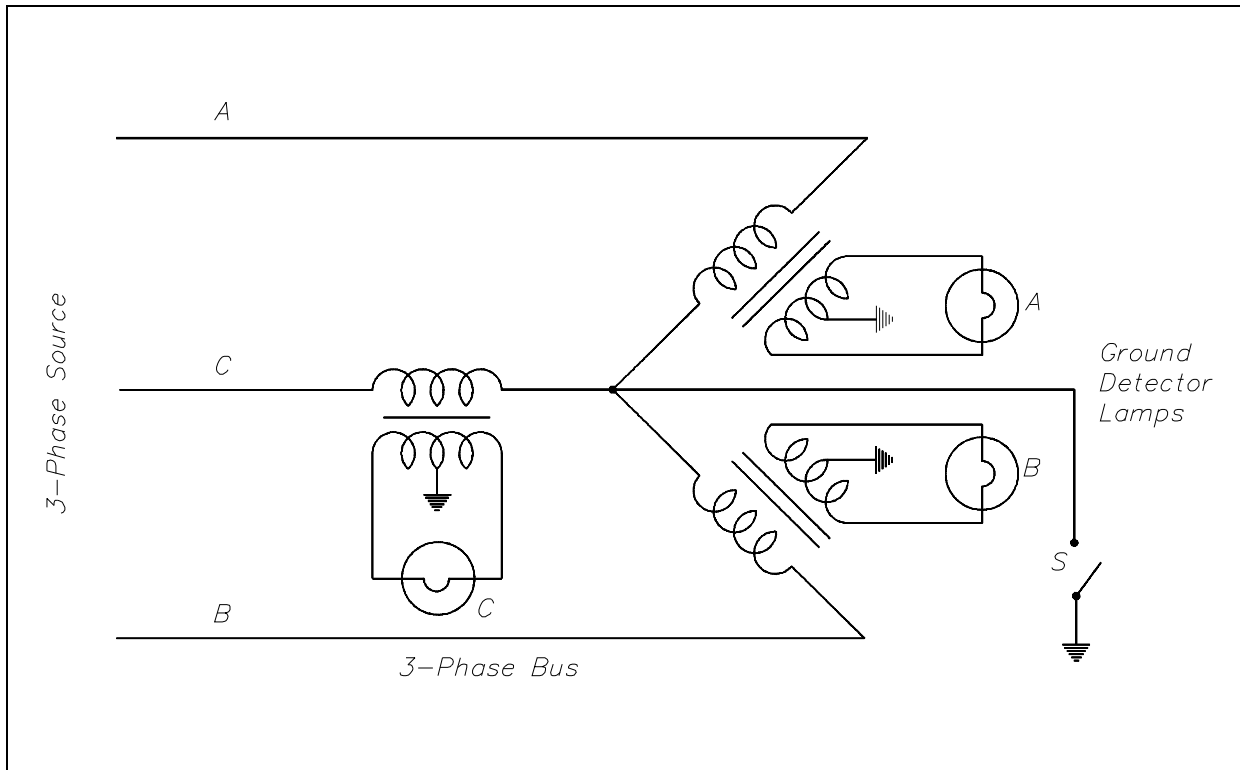

Figure 16 Ground Detector Lamp Circuit

## Synchroscope

A synchroscope indicates when two AC generators are in the correct phase relation for connecting in parallel and shows whether the incoming generator is running faster or slower than the on-line generator. The synchroscope consists of a two-phase stator. The two stator windings are at right angles to one another, and by means of a phase-splitting network, the current in one phase leads the current of the other phase by  $90^\circ$ , thereby generating a rotating magnetic field. The stator windings are connected to the incoming generator, and a polarizing coil is connected to the running generator.

The rotating element is unrestrained and is free to rotate through  $360^\circ$ . It consists of two iron vanes mounted in opposite directions on a shaft, one at the top and one at the bottom, and magnetized by the polarizing coil.

If the frequencies of the incoming and running generators are different, the synchroscope will rotate at a speed corresponding to the difference. It is designed so that if incoming frequency is higher than running frequency, it will rotate in the clockwise direction; if incoming frequency is less than running frequency, it will rotate in the counterclockwise direction. When the synchroscope indicates  $0^\circ$  phase difference, the pointer is at the "12 o'clock" position and the two AC generators are in phase.

## **Summary**

The important information contained in this chapter is summarized below.

### **Measuring Devices Summary**

#### Ampere-hour Meter

- Measures current flow (either direction) through a given point
- Connected in series

#### Power Factor Meter

- Measures power factor between phases in a 3-phase circuit
- Connected in series with one phase

#### Ground Detector

- Measures conductor insulation
- Connected out of circuit to ground

#### Synchroscope

- Measures relationship between generator frequencies
- Connected by a two-phase stator at right angles



## TEST EQUIPMENT

---

*The multimeter can be used as an ammeter, an ohm meter, or a voltmeter.  
Meggers are used to measure insulation resistance.*

**EO 1.3      EXPLAIN how the following electrical test equipment  
and measuring devices are connected to a circuit:**

**i.      Megger**

**EO 1.4      STATE the electrical parameters measured by each of  
the following test instruments:**

**a.      Multimeter**

**b.      Megger**

---

### Multimeter

The multimeter is a portable single instrument capable of measuring various electrical values including voltage, resistance, and current. The volt-ohm-milliammeter (VOM) is the most commonly used multimeter. The typical VOM has a meter movement with a full scale current of 50  $\mu$ A, or a sensitivity of 20  $K\Omega/V$ , when used as a DC voltmeter. A single meter movement is used to measure current, AC and DC voltage, and resistance. Range switches are usually provided for scale selection (e.g., 0-1V, 0-10V, etc).

### Megger

The megger is a portable instrument used to measure insulation resistance. The megger consists of a hand-driven DC generator and a direct reading ohm meter. A simplified circuit diagram of the instrument is shown in Figure 17.

The moving element of the ohm meter consists of two coils, A and B, which are rigidly mounted to a pivoted central shaft and are free to rotate over a C-shaped core (C on Figure 17). These coils are connected by means of flexible leads. The moving element may point in any meter position when the generator is not in operation.

As current provided by the hand-driven generator flows through Coil B, the coil will tend to set itself at right angles to the field of the permanent magnet. With the test terminals open, giving an infinite resistance, no current flows in Coil A. Thereby, Coil B will govern the motion of the rotating element, causing it to move to the extreme counter-clockwise position, which is marked as infinite resistance.

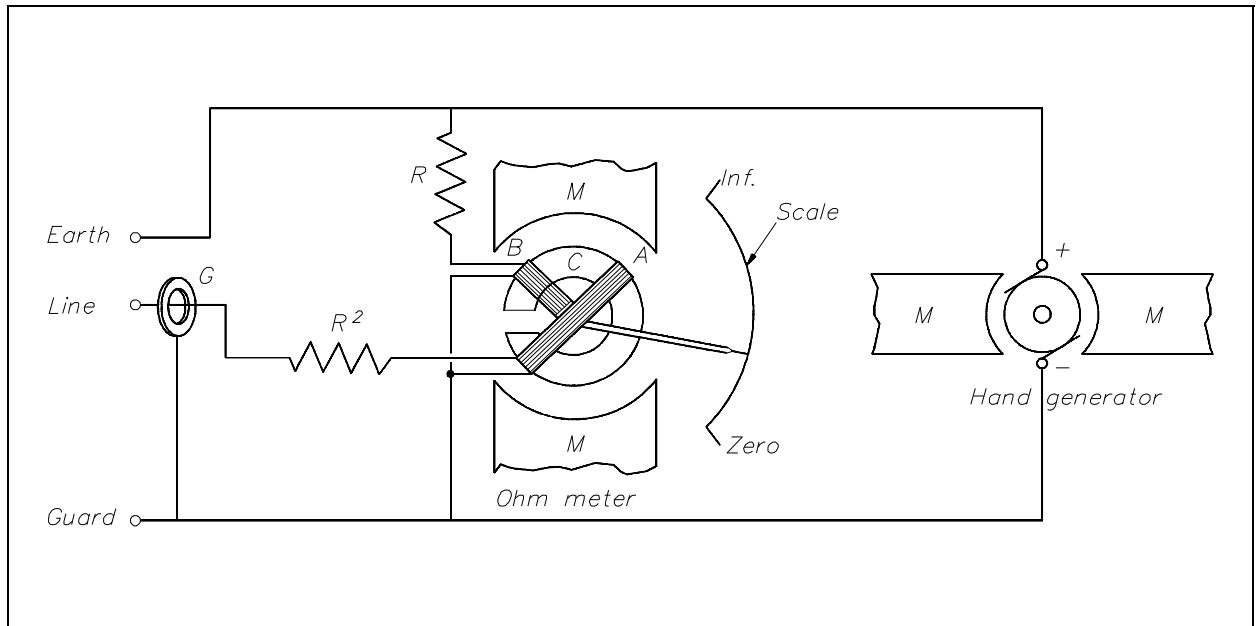

Figure 17 Simple Megger Circuit Diagram

Coil A is wound in a manner to produce a clockwise torque on the moving element. With the terminals marked "line" and "earth" shorted, giving a zero resistance, the current flow through the Coil A is sufficient to produce enough torque to overcome the torque of Coil B. The pointer then moves to the extreme clockwise position, which is marked as zero resistance. Resistance ( $R^1$ ) will protect Coil A from excessive current flow in this condition.

When an unknown resistance is connected across the test terminals, line and earth, the opposing torques of Coils A and B balance each other so that the instrument pointer comes to rest at some point on the scale. The scale is calibrated such that the pointer directly indicates the value of resistance being measured.

## **Summary**

Test equipment is summarized below.

### **Test Equipment Summary**

- Multimeters measure current, voltage, and resistance.
- Meggers measure insulation resistance.
- Meggers are connected out of circuit.